

BUGGISCOPIC

BTI 220/225 BT 420/425

- Lifting height : 4.00 m
- Capacity : 2000/2500 kg
- Maximum reach : 2.70 m/2.83 m
- Hydrostatic transmission



BTI 220 - BTI 225 : 2 wheel drive
BT 420 - BT 425 : 4 wheel drive



Lifting capacity
 at 500 mm from forks heels :
 BTI 220 - BT 420 :2000 kg
 BTI 225 - BT 425 :2500 kg
 Tipping load at maximum reach :
 BTI 220 - BT 4201030 kg
 BTI 225 - BT 4251200 kg
 Tear out force with bucket to
 ISO 83133430 kg



Lifting height :4.00 m
Times : unladen/loaded (ins) :
 Lifting :3.85/4.05
 Lowering :3.17/3.11
 Boom extension :3.96/3.88
 Boom retraction :6.55/6.83
 Time unladen (in s)
 Crowd3,5
 Dump3



Tyres :
 Front: BTI 220/225265/70 R 19.5 XTA
 BT 420/42511.5/80 15.3
 Rear : BTI 220/225700 x 12 IC 40
 BT 420/42528 x 9.15 IC 40



Forks (mm)
 Length :1100
 Width x thickness :100 X 40



Brakes
 Mechanical on front axle



Perkins engine
 Type :104-19
 Capacity :4 cyl. - 1995 cm³
 Power (DIN 6270 B) :39 HP (28.7 kw)
 Maximum torque :119 Nm at 2200 r.p.m.
 Rated speed2800 r.p.m.
 Water cooling



Transmissionhydrostatic
 Electromagnetic reversing shift
 Maximum travel speed :20.5 km/h



Hydraulics
 Lifting/tilting pump
 gear type :230 bars /56.7 l/mn
 Steering pump
 gear type :155 bars /23.1 l/mn



Capacities
 Cooling system8 l.
 Engine oil4.5 l.
 Hydraulic oil55 l.
 Fuel tank54 l.



	BT 420	BTI 220	BT 425	BTI 225
Weight unladen (with forks)	4610 kg	4630 kg	4530 kg	4550 kg
Overall width	1.44 m	1.46 m		
Overall height	1.94 m	1.95 m		
Turning radius (outside wheels)	3.35 m	2.92 m		
Ground clearance	0.24 m	0.23 m		
Drawbar pull	2540 daN	2900 daN		

BTI 225 - BT 425 : 2500 kg
With integral industrial carriage

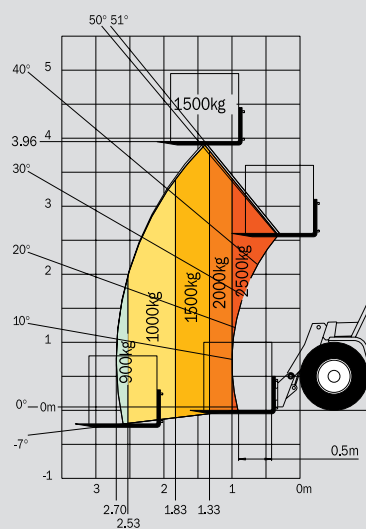

BTI 220 - BT 420 : 2000 kg
With quick fitting carriage

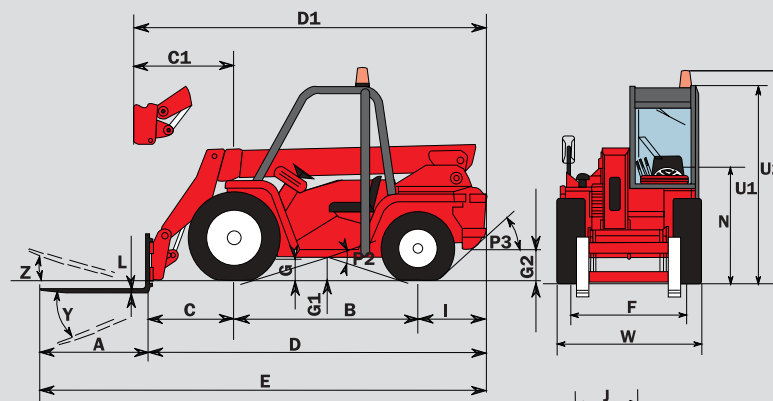
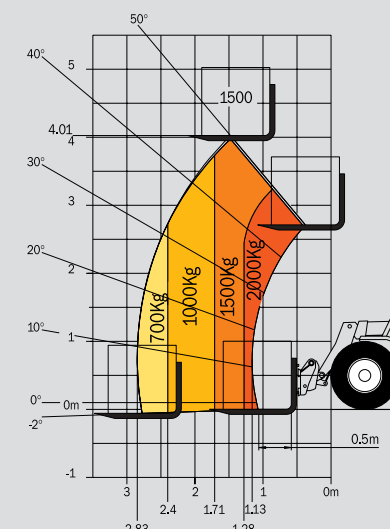

	BTI 220	BTI 225	BT 420	BT 425
A	1100	1100	1100	1100
B	1800	1800	1800	1800
C	1070	896	1065	896
C1	930	-	925	-
D	3540	3381	3550	3381
D1	3400	-	3410	-
E	4640	4480	4650	4480
F	1190	1190	1146	1146
F1	1112	1112	1105	1105
G	225	225	235	235
G1	225	225	235	235
G2	165	165	245	245
I	670	670	685	685
J	640	640	640	640
K	1020	1020	1020	1020
L	40	40	40	40
N	1200	1200	1180	1180
O	100	100	100	100
P2	34°	34°	34°	34°
P3	40°	40°	40°	40°
R	2735	2735	3240	3240
S	5145	4970	5690	5690
T	2540	2540	2200	2200
U1	1955	1955	1980	1980
U2	2115	2115	2140	2140
V	2975	2975	3510	3510
V1	615	615	1250	1250
V2	2915	2915	3350	3350
W	1460	1460	1436	1436
Y	107°	107°	107°	107°
Z	16°	16°	16°	16°

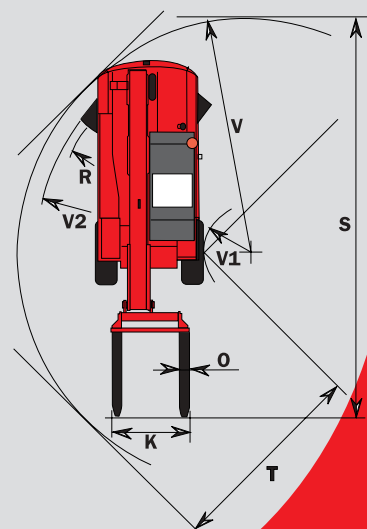
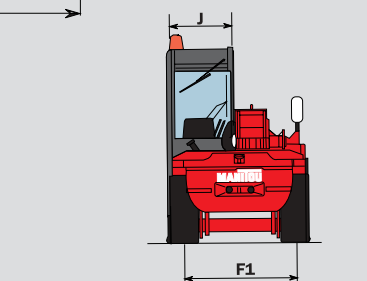

This publication in no way constitutes an offer and the company reserves the right to alter specification without prior notice.
 The MANITOU models presented in this brochure can be supplied complete with optional equipment attachments

